

ISOLATED DC-DC CONVERTER CFDQG150-300S SERIES



Beijing Huayang Changfeng Technology Co., Ltd

Address of China factory: No. 25, Torch South Street, development zone,
Zhuozhou City, Baoding City, Hebei Province, China

WWW.CHAWENS.COM

Contents

1. Introduction	3
2. DC-DC Converter Features.....	3
3. Electrical Block Diagram	3
4. Technical Specifications.....	4
5. Main Features and Functions.....	8
5.1 Operating Temperature Range	8
5.2 Output Voltage Adjustment	8
5.3 Over Current Protection	8
5.4 Output Over Voltage Protection	8
5.5 Remote On/Off	8
5.6 UVLO (Under Voltage Lock Out)	8
5.7 Over Temperature Protection.....	9
6. Applications.....	9
6.1 Recommend Layout, PCB Footprint, Cleaning and Soldering Information	9
6.2 Connection for Standard Use.....	10
6.3 Input Capacitance at the Power Module	10
6.4 Convection Requirements for Cooling	10
6.5 Thermal Considerations	10
6.6 Power Derating	11
6.7 Quarter Brick Heat Sinks:.....	13
6.8 Efficiency VS. Load	14
6.9 Test Set-Up	15
6.10 Output Voltage Adjustment	15
6.11 Output Remote Sensing.....	16
6.12 Output Ripple and Noise	17
6.13 Output Capacitance	18
6.14 Remote On/Off Circuit.....	18
6.15 Series Operation	18
6.16 Parallel/Redundant Operation.....	19
7. Safety & EMC	20
7.1 Input Fusing and Safety Considerations	20
7.2 AC INPUT EMC Considerations	21
7.3 DC INPUT EMC Considerations	25
8. Part Number.....	29
9. Mechanical Specifications.....	29
9.1 Mechanical Outline Diagrams	29

Model Number	Input Voltage	Output Voltage	Output Current		Input Current		% EFF.	Capacitor Load Max.
			Min.	Max.	No Load	Full Load		
CFDQG150-300S05X	180-425V _{DC}	5V _{DC}	0mA	30A	10mA	580mA	86	10000μF
CFDQG150-300S12X		12V _{DC}		12.5A		560mA	89	8800μF
CFDQG150-300S15X		15V _{DC}		10A		560mA	89	8800μF
CFDQG150-300S24X		24V _{DC}		6.3A		570mA	88.5	3300μF
CFDQG150-300S28X		28V _{DC}		5.4A		570mA	88.5	3300μF
CFDQG150-300S48X		48V _{DC}		3.2A		570mA	89	1000μF

NOTE:

1. Nominal Input Voltage 300V_{DC}
2. Require a Ceramic Capacitor 1500pF Connected Between –Vin to Case for All Models.
3. An External Input Capacitor 68uF for All Models are Recommended to Reduce Input Ripple Voltage.
4. Measure at Nominal Input Voltage.

1. Introduction

The CFDQG150-300S Series is an industry standard quarter-brick DC-DC converter, providing up to 150W of output power @ single output voltages of 5,12,15, 24,28,48V_{DC}. It has a high input voltage range of 180 to 425V_{DC}(300V_{DC} nominal)and reinforced with a 3000V_{AC} isolation.

High efficiency up to 89%, allowing case operating temperature range of -40°C to 100°C. An optional heat sink is available to extend the full power range of the unit. Very low no load power consumption(10mA), an ideal solution for energy critical system applications.

The standard control functions include remote on/off (positive or negative) and 80-110% adjustable output voltage.

Fully protected against input UVLO (under voltage lock out), input over-voltage, output over-current, output over-voltage and over-temperature and continuous short circuit conditions.

All models are highly suitable for distributed power architectures, telecommunications, servers, base station, battery operated equipment, and industrial applications.

2. DC-DC Converter Features

- 150W Isolated Output
- Efficiency up to 89%
- Fixed Switching Frequency
- Regulated Outputs
- Remote On/Off
- Low No Load Power Consumption
- Over Temperature Protection
- Over Voltage/Current Protection
- Continuous Short Circuit Protection
- Quarter Brick Size meet industrial standard
- UL62368-1 (Reinforced Insulation) Approval
- CB Test Certificate IEC62368-1
- Shock & Vibration Meets EN50155 (EN61373)
- Fire & Smoke Meets EN45545-2

4. Technical Specifications

(All specifications are typical at nominal input, full load at 25°C unless otherwise noted.)

ABSOLUTE MAXIMUM RATINGS

PARAMETER	NOTES and CONDITIONS	Device	Min.	Typ.	Max.	Units
Input Voltage						
Continuous		All	-0.3		425	V _{DC}
Transient	100ms	All			500	V _{DC}
Operating Case Temperature		All	-40		105	°C
Storage Temperature		All	-55		125	°C
Isolation Voltage	1 minute; Input/output	All			3000	V _{AC}
	1 minute; Input/case				2500	
	1 minute; Output/case				500	

INPUT CHARACTERISTICS

PARAMETER	NOTES and CONDITIONS	Device	Min.	Typ.	Max.	Units
Operating Input Voltage		All	180	300	425	V _{DC}
Input Under Voltage Lockout						
Turn-On Voltage Threshold		All	165	170	175	V _{DC}
Turn-Off Voltage Threshold		All	155	160	165	V _{DC}
Lockout Hysteresis Voltage		All		10		V _{DC}
Maximum Input Current	100% Load, V _{in} =180V for All	All		1		A
No-Load Input Current		V _o =5.0V		10		mA
		V _o =12V		10		
		V _o =15V		10		
		V _o =24V		10		
		V _o =28V		10		
		V _o =48V		10		
Input Filter	Pi filter.	All				
Inrush Current (I ² t)	As per ETS300 132-2.	All			0.1	A ² s
Input Reflected Ripple Current	P-P thru 12uH inductor, 5Hz to 20MHz See 6.3	All		30		mA

OUTPUT CHARACTERISTICS

PARAMETER	NOTES and CONDITIONS	Device	Min.	Typ.	Max.	Units
Output Voltage Set Point	$V_{in} = \text{Nominal } V_{in}, I_o = I_{o_max}, T_c = 25^\circ\text{C}$	$V_o = 5.0\text{V}$	4.95	5	5.05	V_{DC}
		$V_o = 12\text{V}$	11.88	12	12.12	
		$V_o = 15\text{V}$	14.85	15	15.15	
		$V_o = 24\text{V}$	23.76	24	24.24	
		$V_o = 28\text{V}$	27.72	28	28.28	
		$V_o = 48\text{V}$	47.52	48	48.48	
Output Voltage Regulation						
Load Regulation	$I_o = I_{o_min}$ to I_{o_max}	All			± 0.2	%
Line Regulation	$V_{in} = \text{low line to high line}$	All			± 0.2	%
Temperature Coefficient	$T_c = -40^\circ\text{C}$ to 105°C	All			± 0.02	%/ $^\circ\text{C}$
Output Voltage Ripple and Noise (5Hz to 20MHz bandwidth)						
Peak-to-Peak	Full load, 10uF tantalum and 1uF ceramic capacitors (for $V_o = 48\text{V}$: Full Load 10uF aluminum and 1uF ceramic). See 6.12	$V_o = 5.0\text{V}$			100	mV
		$V_o = 12\text{V}$			150	
		$V_o = 15\text{V}$			150	
		$V_o = 24\text{V}$			280	
		$V_o = 28\text{V}$			280	
		$V_o = 48\text{V}$			480	
RMS.	Full load, 10uF tantalum and 1uF ceramic capacitors (for $V_o = 48\text{V}$: Full Load 10uF aluminum and 1uF ceramic). See 6.12	$V_o = 5.0\text{V}$			60	mV
		$V_o = 12\text{V}$			60	
		$V_o = 15\text{V}$			60	
		$V_o = 24\text{V}$			100	
		$V_o = 28\text{V}$			100	
		$V_o = 48\text{V}$			200	
Operating Output Current Range		$V_o = 5.0\text{V}$	0		30	A
		$V_o = 12\text{V}$	0		12.5	
		$V_o = 15\text{V}$	0		10	
		$V_o = 24\text{V}$	0		6.3	
		$V_o = 28\text{V}$	0		5.4	
		$V_o = 48\text{V}$	0		3.2	
Output DC Current Limit Inception	Hiccup Mode. Auto recovery. See 5.3	All	110	125	160	%
Maximum Output Capacitance	Full load (resistive)	$V_o = 5.0\text{V}$	0		10000	μF
		$V_o = 12\text{V}$	0		8800	
		$V_o = 15\text{V}$	0		8800	
		$V_o = 24\text{V}$	0		3300	
		$V_o = 28\text{V}$	0		3300	
		$V_o = 48\text{V}$	0		1000	
Output Voltage Trim Range	$P_{out} = \text{max rated power}$, See 6.10	All	-20		+10	%
Output Over Voltage Protection	Limited Voltage, See 5.4	All	115	125	140	%

DYNAMIC CHARACTERISTICS

PARAMETER	NOTES and CONDITIONS	Device	Min.	Typ.	Max.	Units
Output Voltage Current Transient						
Error Band	75% to 100% of I_{o_max} step load change $d_i/d_t=0.1A/us$ (within 1% V_{out} nominal)	All			±5	%
Recovery Time		All			250	us
Turn-On Delay and Rise Time	Full load (Constant resistive load)					
Turn-On Delay Time, From On/Off Control	$V_{on/off}$ to 10% V_{o_set}	All		250		ms
Turn-On Delay Time, From Input	V_{in_min} to 10% V_{o_set}	All		250		ms
Output Voltage Rise Time	10% V_{o_set} to 90% V_{o_set}	All		30		ms

EFFICIENCY

PARAMETER	NOTES and CONDITIONS	Device	Min.	Typ.	Max.	Units
100% Load	$V_{in}=300V$ See 6.8	$V_o=5.0V$		86		%
		$V_o=12V$		89		
		$V_o=15V$		89		
		$V_o=24V$		88.5		
		$V_o=28V$		88.5		
		$V_o=48V$		89		

ISOLATION CHARACTERISTICS

PARAMETER	NOTES and CONDITIONS	Device	Min.	Typ.	Max.	Units
Isolation Voltage	1 minute; input/output 1 minute; input/case 1 minute; output/case	All			3000 2500 500	V_{AC}
Isolation Resistance	Input/output	All	100			MΩ
Isolation Capacitance	Input/output Input/case Output/case	All		NC NC 0.01		uF

FEATURE CHARACTERISTICS

PARAMETER	NOTES and CONDITIONS	Device	Min.	Typ.	Max.	Units
Switching Frequency	Pulse wide modulation (PWM), Fixed	All	330	360	390	KHz
On/Off Control, Positive Remote On/Off Logic, Refer to $-V_{in}$ Pin						
Logic Low (ModuleOff)	$V_{on/off}$ at $I_{on/off}=1.0mA$	All	0		1.2	V
Logic High (Module On)	$V_{on/off}$ at $I_{on/off}=0.0uA$	All	3.5 or Open Circuit		75	V
On/Off Control, Negative Remote On/Off Logic, Refer to $-V_{in}$ Pin						
Logic High (ModuleOff)	$V_{on/off}$ at $I_{on/off}=0.0uA$	All	3.5 or Open Circuit		75	V
Logic Low (Module On)	$V_{on/off}$ at $I_{on/off}=1.0mA$	All	0		1.2	V

PARAMETER	NOTES and CONDITIONS	Device	Min.	Typ.	Max.	Units
On/Off Current (for both remote on/off logic)	$I_{on/off}$ at $V_{on/off}=0.0V$	All		0.3	1	mA
Leakage Current (for both remote on/off logic)	Logic High, $V_{on/off}=15V$	All			30	uA
Off Converter Input Current	Shutdown input idle current	All		2.5	4	mA
Output Voltage Trim Range	$P_{out}=\text{max rated power}$	All	-20		+10	%
Output Over Voltage Protection		All	115	125	140	%
Over Temperature Shutdown	Aluminum baseplate temperature	All		110		°C
Over Temperature Recovery		All		100		°C

GENERAL SPECIFICATIONS

PARAMETER	NOTES and CONDITIONS	Device	Min.	Typ.	Max.	Units
MTBF	$I_o=100\%$ of I_{o_max} ; MIL - HDBK - 217F_Notice 1,GB, 25°C	300S48 Others		1000 800		K hours
Weight		All		65		grams
Case Material	Plastic, DAP					
Baseplate Material	Aluminum					
Potting Material	UL 94V-0					
Pin Material	Base: Copper Plating: Nickel with Matte Tin					
Shock/Vibration	MIL-STD-810F/EN61373					
Humidity	95% RH max. Non Condensing					
Altitude	2000m Operating Altitude, 12000m Transport Altitude					
Thermal Shock	MIL-STD-810F					
EMI	Meets EN55011, EN55032 with external input filter, see 7.2					
ESD	IEC61000-4-2 Level3:Air $\pm 8kV$, Contact $\pm 6kV$					Class A
Radiated immunity	IEC61000-4-3 Level3:80~1000MHz, 20V/m					Perf.Criteria A
Fast Transient	IEC61000-4-4 Level3:On power input port, $\pm 2kV$, external input capacitor required, see 7.1					Perf.Criteria A
Surge	IEC61000-4-5 Level 4: Line to earth, $\pm 4kV$, Line to line, $\pm 2kV$					Perf.Criteria A
Conducted immunity	EN61000-4-6 Level 3: 0.15~80MHz, 10V					Perf.Criteria A
Power Frequency Magnetic Field immunity	IEC61000-4-8 50/60Hz, 3A/m (r.m.s.)					Perf.Criteria A

5. Main Features and Functions

5.1 Operating Temperature Range

The CFDQG150-300 series converters can be operated within a wide case temperature range of -40°C to 100°C . Consideration must be given to the derating curves when ascertaining maximum power that can be drawn from the converter. The maximum power drawn from open quarter brick models is influenced by usual factors, such as:

- Input voltage range
- Output load current
- Forced air or natural convection
- Heat sink optional

5.2 Output Voltage Adjustment

Section 6.10 describes in detail how to trim the output voltage with respect to its set point. The output voltage on all models is adjustable within the range of $+10\%$ to -20% .

5.3 Over Current Protection

All models have internal over current and continuous short circuit protection. The unit operates normally once the fault condition is removed. At the point of current limit inception, the converter will go into hiccup mode protection.

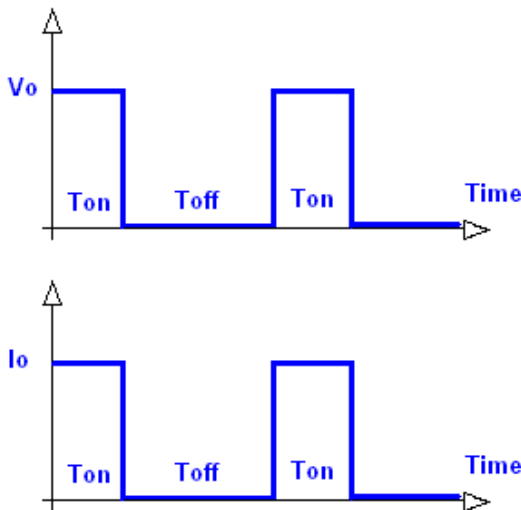

5.4 Output Over Voltage Protection

The output over voltage protection consists of circuitry that internally limits the output voltage. If more accurate output over voltage protection is required then an external circuit can be used via the remote on/off pin.

Note: Please note that device inside the power supply might fail when voltage more than rate output voltage is applied to output pin. This could happen when the customer tests the over voltage protection of unit.

5.5 Remote On/Off

The CFDQG150-300 series allows the user to switch the module on and off electronically with the remote on/off feature. All models are available in "positive logic" and "negative logic" (optional) versions. The converter turns on if the remote On/Off pin is high ($>3.5\text{Vdc}$ to 75Vdc or open circuit). Setting the pin low (0 to $<1.2\text{Vdc}$) will turn the converter off. The signal level of the remote on/off input is defined with respect to ground. If not using the remote on/off pin, leave the pin open (converter will be on). Models with part number suffix "N" are the "negative logic" remote On/Off version. The unit turns off if the remote On/Off pin is high ($>3.5\text{VDC}$ to 75VDC or open circuit). The converter turns on if the On/Off pin input is low (0 to $<1.2\text{VDC}$). Note that the converter is off by default. See 6.14

Logic State (Pin 2)	Negative Logic	Positive Logic
Logic Low – Switch Closed	Module on	Module off
Logic High – Switch Open	Module off	Module on

5.6 UVLO (Under Voltage Lock Out)

Input under voltage lockout is standard on the CFDQG150-300S unit. The unit will shut down when the input voltage drops below a threshold, and the unit will operate when the input voltage goes above the upper threshold.

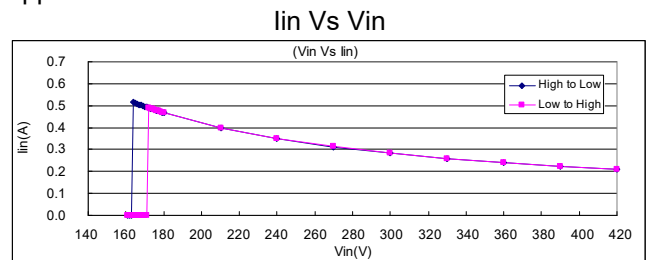

5.7 Over Temperature Protection

These modules have an over temperature protection circuit to safeguard against thermal damage. Shutdown occurs with the maximum case reference temperature is exceeded. The module will restart when the case temperature falls below over temperature recovery threshold. Please measure case temperature of the center part of aluminum baseplate.

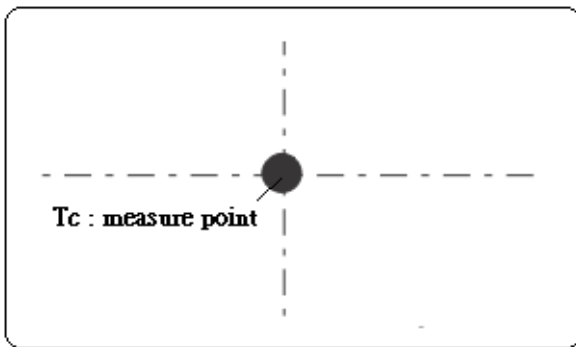
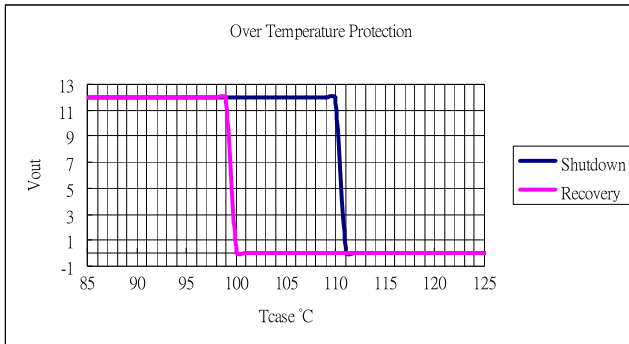

The suggested soldering iron is 450°C for up to 5seconds (less than 50W). Furthermore, the recommended solde ring profile and PCB layout are shown below.

Lead Free Wave Soldering Profile

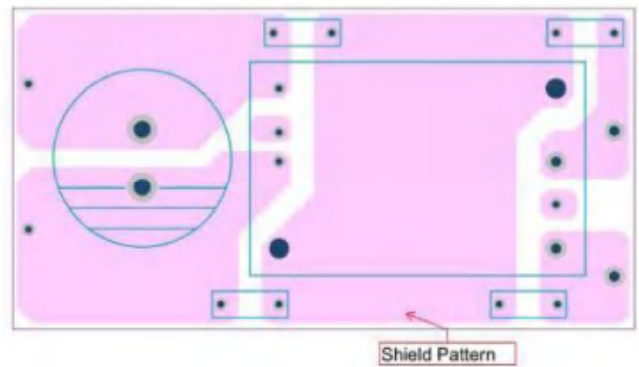
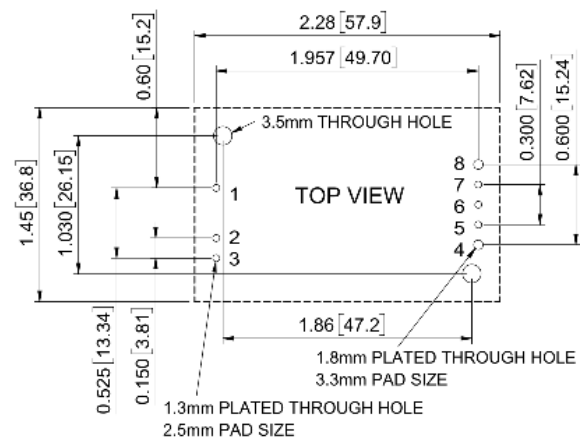
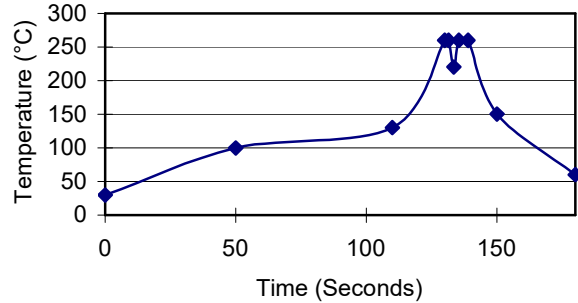

6. Applications

6.1 Recommend Layout, PCB Footprint, Cleaning and Soldering Information

The system designer or end user must ensure that metal and other components in the vicinity of the converter meet the spacing requirements for which the system is approved. Low resistance and inductance PCB layout traces are the norm and should be used where possible. Due consideration must also be given to proper low impedance tracks between power module, input and output grounds.

Clean the soldered side of the module with a brush, prevent liquid from getting into the module. Do not clean by soaking the module into liquid. Do not allow solvent to come in contact with product labels or resin case as this may change the color of the resin case or cause deletion of the letters printed on the product label. After cleaning, dry the modules well.

6.2 Connection for Standard Use

The connection for standard use is shown below. An external input capacitor (C1) 68uF for all models is recommended to reduce input ripple voltage. External output capacitors (C2, C3) are recommended to reduce output ripple and noise, 10uF aluminum and 1uF ceramic capacitor for 48Vout, and 10uF tantalum and 1uF ceramic capacitor for other models.

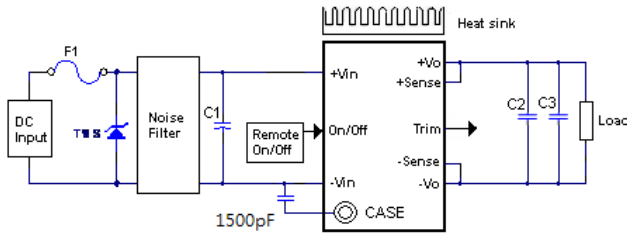

Symbol	Component	Reference
F1, TVS	Input fuse, TVS	Section 7.1
C1	External capacitor on input side	Note
C2, C3	External capacitor on the output side	Section 6.12/6.13
Noise Filter	External input noise filter	Section 7.2
Remote On/Off	External Remote On/Off control	Section 6.14
Trim	External output voltage adjustment	Section 6.10
Heat sink	External heat sink	Section 6.4/6.5/6.6/6.7
+Sense/-Sense	--	Section 6.11

Note:

An external input capacitor 68uF (Nippon Chemi-Con KXG or KXJ series) for all models are recommended to reduce input ripple voltage. If the impedance of input line is high, C1 capacitance must be more than above. Use more than two recommended capacitor above in parallel when ambient temperature becomes lower than -20°C.

6.3 Input Capacitance at the Power Module

The converters must be connected to low AC source impedance. To avoid problems with loop stability source inductance should be low. Also, the input capacitors (Cin) should be placed close to the converter input pin to decouple distribution inductance. However, the external input capacitors are chosen for suitable ripple handling capability. Low ESR capacitors are good choice. Circuit as shown below represents typical measurement methods for reflected ripple current. C1 and L1 simulate a typical DC source impedance. The input reflected-ripple current is measured by current probe to oscilloscope with a simulated source inductance (L1).

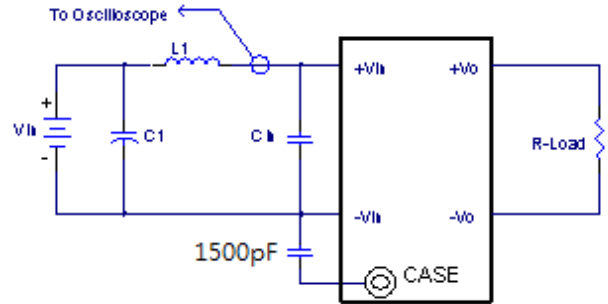

L1: 12uH
 C1: 330uF ESR < 0.7ohm @ 100KHz
 Cin: 180uF ESR < 0.7ohm @ 100KHz

6.4 Convection Requirements for Cooling

To predict the approximate cooling needed for the quarter brick module, refer to the power derating curves in section 6.6. These derating curves are approximations of the ambient temperatures and airflows required to keep the power module temperature below its maximum rating. Once the module is assembled in the actual system, the module's temperature should be monitored to ensure it does not exceed 105°C as measured at the center of the top of the case (thus verifying proper cooling).

6.5 Thermal Considerations

The power module operates in a variety of thermal environments; however, sufficient cooling should be provided to help ensure reliable operation of the unit. Heat is removed by conduction, convection, and radiation to the surrounding environment. The example is presented in section 6.6. The power output of the module should not be allowed to exceed rated power ($V_{o_set} \times I_{o_max}$).

6.6 Power Derating

The operating case temperature range of CFDQG150-300 series is -40°C to $+100^{\circ}\text{C}$. When operating the CFDQG150-300 series, proper derating or cooling is needed. The maximum case temperature under any operating condition should not exceed 100°C .

The following curve is the de-rating curve of CFDQG150-300S series without heat sink.

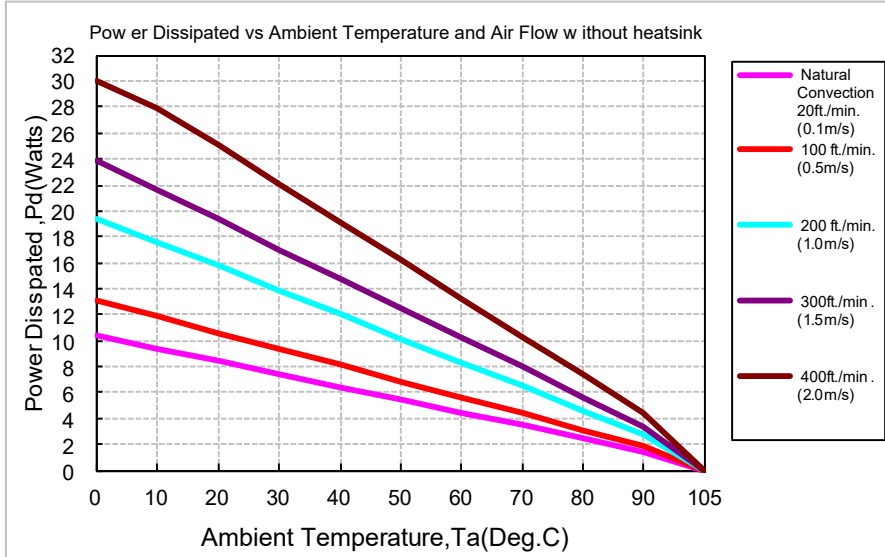

AIR FLOW RATE	TYPICAL R_{ca}
Natural Convection	
20ft./min. (0.1m/s)	10.1°C/W
100 ft./min. (0.5m/s)	8.0°C/W
200 ft./min. (1.0m/s)	5.4°C/W
300 ft./min. (1.5m/s)	4.4°C/W
400 ft./min. (2.0m/s)	3.4°C/W

Example:

What is the minimum airflow necessary for a CFDQG150-300S12 operating at nominal line voltage, an output current of 12.5A, and a maximum ambient temperature of 40°C

Solution:

Given:

$$V_{in}=300V_{DC}, V_o=12V_{DC}, I_o=12.5A$$

Determine Power dissipation (P_d):

$$P_d = P_i - P_o = P_o(1-\eta)/\eta$$

$$P_d = 12V \times 12.5A \times (1-0.89)/0.89 = 18.54\text{Watts}$$

Determine airflow:

$$\text{Given: } P_d = 18.54\text{W and } T_a = 40^{\circ}\text{C}$$

Check Power Derating curve:

$$\text{Minimum airflow} = 400 \text{ ft./min.}$$

Verify:

Maximum temperature rise is

$$\Delta T = P_d \times R_{ca} = 18.54\text{W} \times 3.4 = 63.04^{\circ}\text{C}.$$

Maximum case temperature is

$$T_c = T_a + \Delta T = 103.04^{\circ}\text{C} < 105^{\circ}\text{C}.$$

Where:

The R_{ca} is thermal resistance from case to ambient environment.

T_a is ambient temperature and T_c is case temperature.

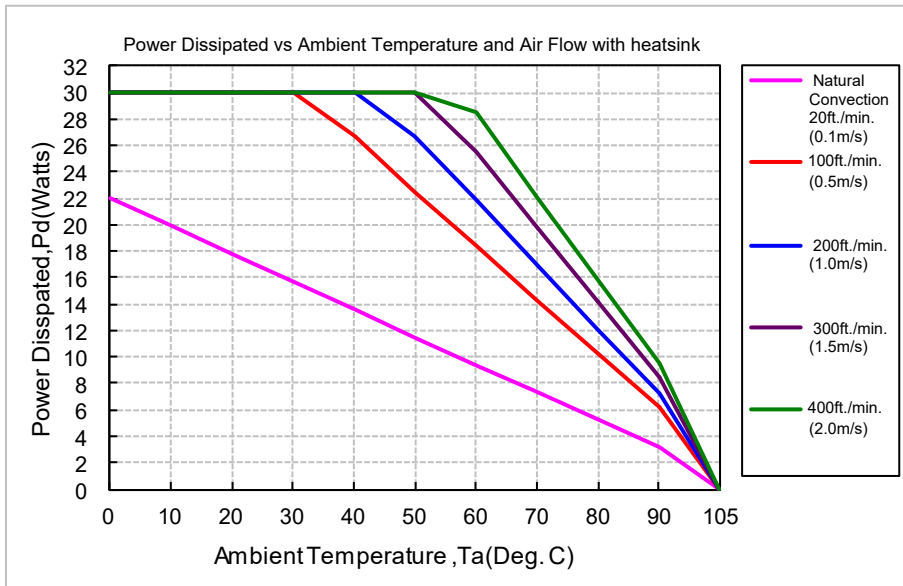

AIR FLOW RATE	TYPICAL R_{ca}
Natural Convection	
20ft./min.(0.1m/s)	4.78°C/W
100ft./min.(0.5m/s)	2.44°C/W
200ft./min.(1.0m/s)	2.06°C/W
300ft./min.(1.5m/s)	1.76°C/W
400ft./min.(2.0m/s)	1.58°C/W

Example with heat sink QBT210 (M-C421):

What is the minimum airflow necessary for a CFDQG150-300S12 operating at nominal line voltage, an output current of 30A, and a maximum ambient temperature of 40°C

Solution:

Given:

$$V_{in}=300V_{bc}, V_o=12V_{bc}, I_o=12.5A$$

Determine Power dissipation (P_d):

$$P_d = P_i - P_o = P_o(1-\eta)/\eta$$

$$P_d = 5.0 \times 30 \times (1-0.89)/0.89 = 18.54 \text{ Watts}$$

Determine airflow:

$$\text{Given: } P_d=18.54W \text{ and } T_a=40^\circ C$$

Check above Power de-rating curve:

$$\text{Minimum airflow} = 100 \text{ ft./min}$$

Verify:

$$\text{Maximum temperature rise is } \Delta T = P_d \times R_{ca} = 18.54 \times 2.44 = 45.24^\circ C$$

$$\text{Maximum case temperature is } T_c = T_a + \Delta T = 85.24^\circ C < 105^\circ C$$

Where:

The R_{ca} is thermal resistance from case to ambient environment.

T_a is ambient temperature and T_c is case temperature.

6.7 Quarter Brick Heat Sinks:

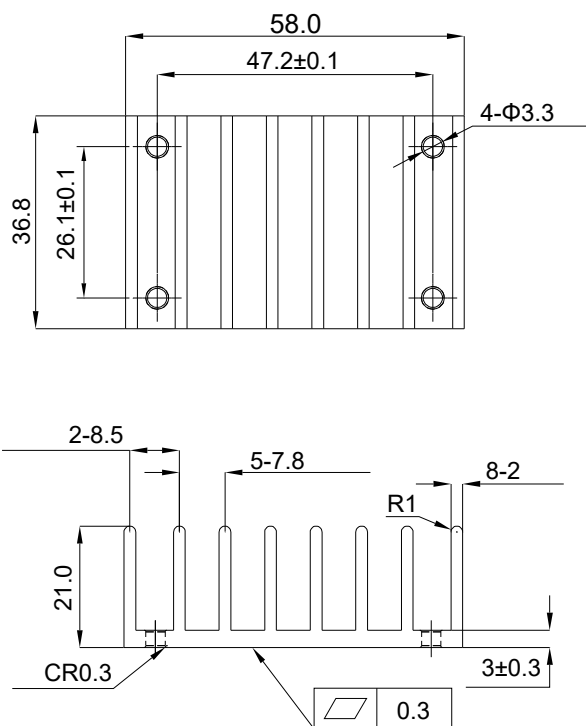

All Dimensions in mm

QBT210 (M-C421):G6620510201

Transverse Heat Sink

Rca: 4.78°C/W (typ.), At natural convection

2.44°C/W (typ.), At 100LFM

2.06°C/W (typ.), At 200LFM

1.76°C/W (typ.), At 300LFM

1.58°C/W (typ.), At 400LFM

6.8 Efficiency VS. Load

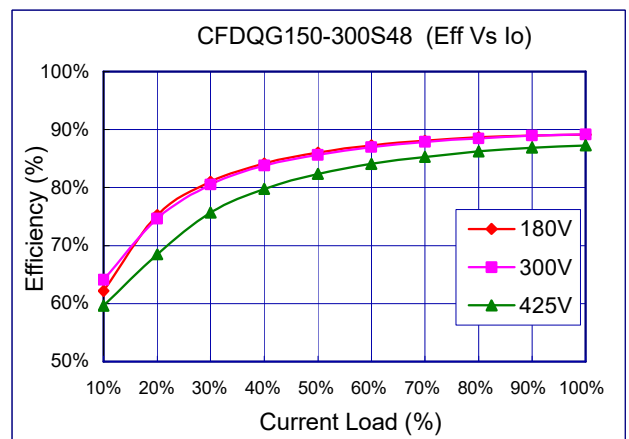
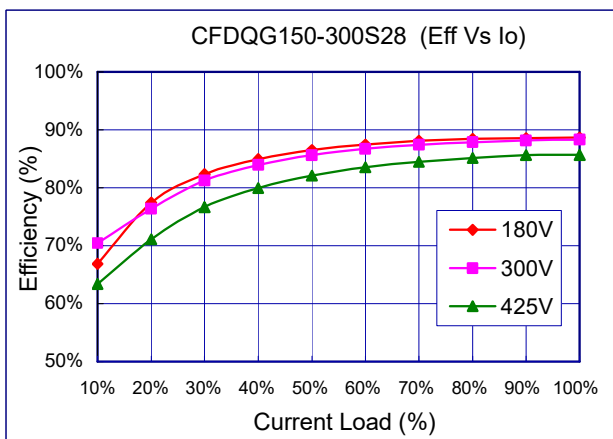
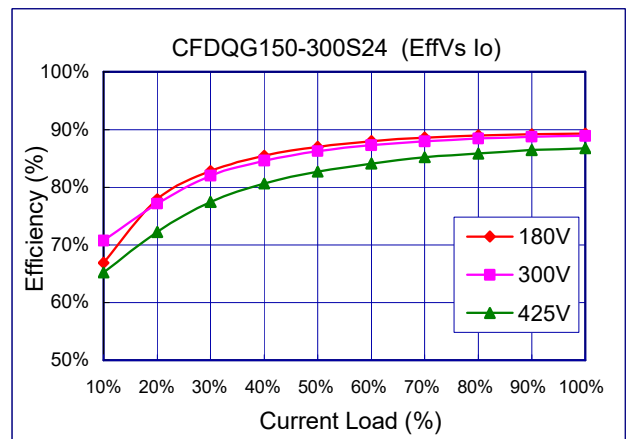
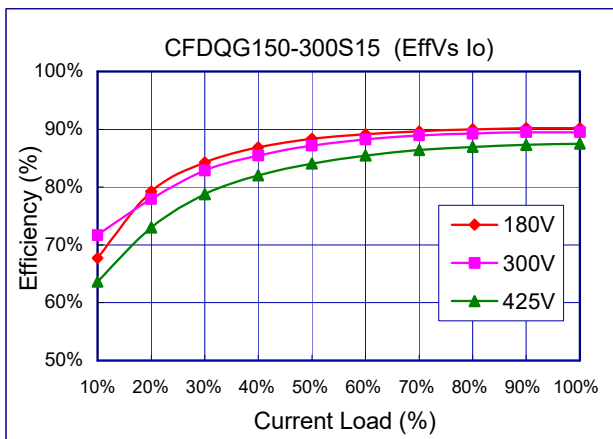
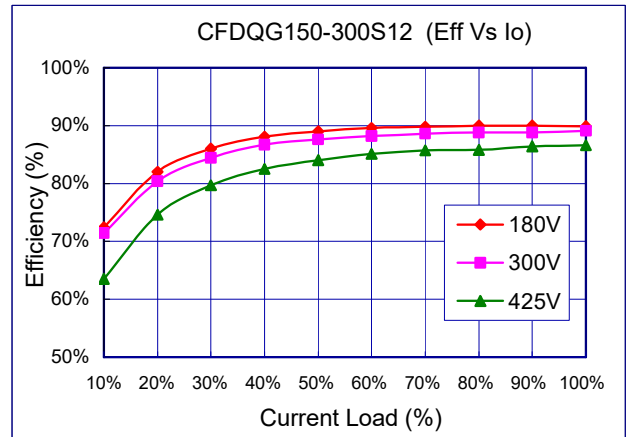
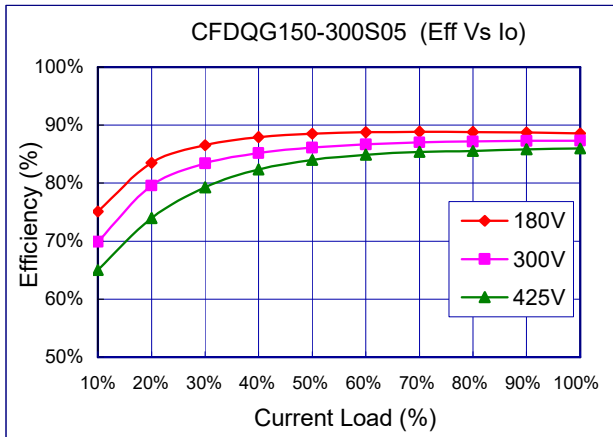

6.9 Test Set-Up

The basic test set-up to measure parameters such as efficiency and load regulation is shown below. When testing the modules under any transient conditions please ensure that the transient response of the source is sufficient to power the equipment under test. We can calculate:

- Efficiency
- Load regulation and line regulation.

The value of efficiency is defined as:

$$\eta = \frac{V_o \times I_o}{V_{in} \times I_{in}} \times 100\%$$

Where:

- V_o is output voltage,
- I_o is output current,
- V_{in} is input voltage,
- I_{in} is input current.

The value of load regulation is defined as:

$$\text{Load.reg} = \frac{V_{FL} - V_{NL}}{V_{NL}} \times 100\%$$

Where:

- V_{FL} is the output voltage at full load
- V_{NL} is the output voltage at no load

The value of line regulation is defined as:

$$\text{Line.reg} = \frac{V_{HL} - V_{LL}}{V_{LL}} \times 100\%$$

Where:

- V_{HL} is the output voltage of maximum input voltage at full load. V_{LL} is the output voltage of minimum input voltage at full load.

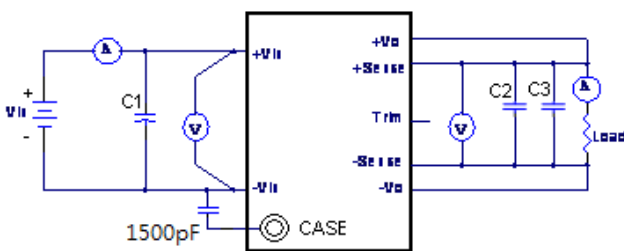

CFDQG150-300S Series Test Setup

- C1: 68uF/450V ESR<0.7Ω
- C2: 1uF/ 1210 ceramic capacitor
- C3: 10uF aluminum capacitor for 48Vout. 10uF tantalum capacitor for others.

6.10 Output Voltage Adjustment

Output may be externally trimmed (+10%/-20%) with a fixed resistor or an external trim pot as shown (optional). Model specific formulas for calculating trim resistors are available upon request as a separate document.

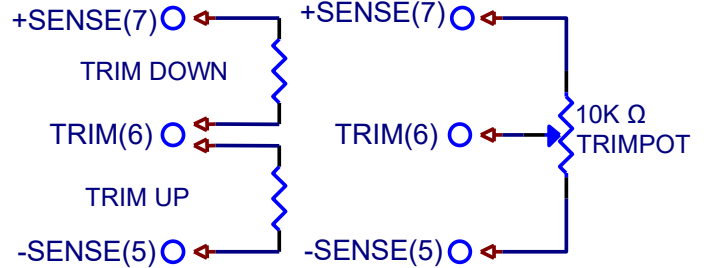

In order to trim the voltage up or down, one needs to connect the trim resistor either between the trim pin and -Sense for trim-up or between trim pin and +Sense for trim-down. The output voltage trim range is +10%/-20%. This is shown:

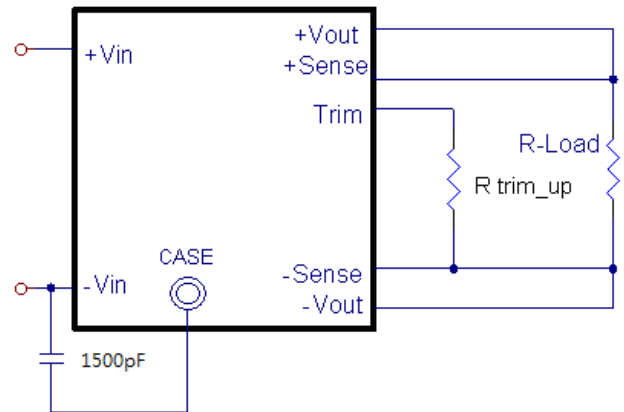

Trim-up Voltage Setup

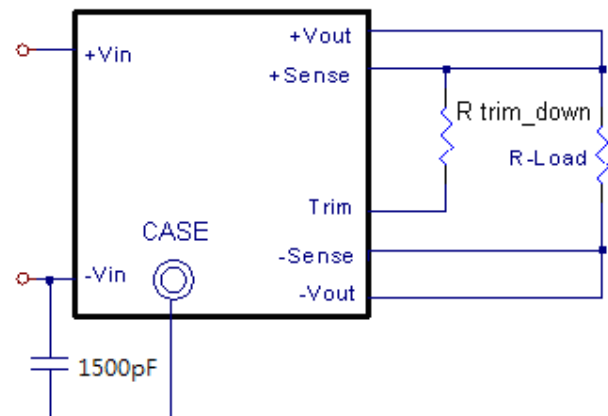

Trim-down Voltage Setup

V _{out} (V)	R1(KΩ)	R2(KΩ)	R3(KΩ)	V _r (V)	V _f (V)
5V	2.32	1.8	0	2.5	0
12V	9.1	24	5.1	2.5	0.5
15V	12	36	8.25	2.5	0.5
24V	20	68	7.5	2.5	0.5
28V	23.7	68	6.2	2.5	0.5
48V	36	82	5.1	2.5	0.5

Trim Resistor Values

The value of R_{trim_up} defined as:

For V_o=5V R_{trim_up} decision:

$$R_{trim_up} = \frac{R_1 V_r}{V_o - V_{o_nom}} - R_2 \quad (\text{K}\Omega)$$

For others R_{trim_up} decision:

$$R_{trim_up} = \left(\frac{R_1 (V_r - V_f \left(\frac{R_2}{R_2 + R_3} \right))}{V_o - V_{o_nom}} \right) - \frac{R_2 R_3}{R_2 + R_3} \quad (\text{K}\Omega)$$

Where:

R_{trim_up} is the external resistor in KΩ.

V_{o_nom} is the nominal output voltage.

V_o is the desired output voltage.

R1, R2, R3 and V_r are internal components.

For example, to trim-up the output voltage of 12V module(CFDQG150-300S12) by 5% to 12.6V, R_{trim_up} is calculated as follows:

$$V_o - V_{o_nom} = 12.6 - 12 = 0.6\text{V}$$

$$R_1 = 9.1 \text{ K}\Omega, R_2 = 24 \text{ K}\Omega, R_3 = 5.1 \text{ K}\Omega,$$

$$V_r = 2.5 \text{ V}, V_f = 0.5 \text{ V}$$

$$R_{trim_up} = \frac{18.997}{0.6} - 4.206 = 27.45(\text{K}\Omega)$$

The value of R_{trim_down} defined as:

$$R_{trim_down} = \frac{R_1 \times (V_o - V_r)}{V_{o_nom} - V_o} - R_2 \quad (\text{K}\Omega)$$

Where:

R_{trim_down} is the external resistor in KΩ.

V_{o_nom} is the nominal output voltage.

V_o is the desired output voltage.

R1, R2, R3 and V_r are internal components.

For example: to trim-down the output voltage of 12V module(CFDQG150-300S12) by 5% to 11.4V, R_{trim_down} is calculated as follows:

$$V_{o_nom} - V_o = 12 - 11.4 = 0.6 \text{ V}$$

$$R_1 = 9.1 \text{ K}\Omega, R_2 = 24 \text{ K}\Omega, V_r = 2.5 \text{ V}$$

$$R_{trim_down} = \frac{9.1 \times (11.4 - 2.5)}{0.6} - 24 = 110.98(\text{K}\Omega)$$

The typical value of R_{trim_up}

	5V	12V	15V	24V	28V	48V
Trim up%	R _{trim_up} (KΩ)					
1%	114.2	154.1	160.7	164.0	167.1	147.3
2%	56.20	74.95	77.01	78.64	80.72	71.29
3%	36.86	48.56	49.10	50.18	51.92	45.93
4%	27.20	35.37	35.15	35.94	37.52	33.24
5%	21.40	27.45	26.78	27.40	28.88	25.63
6%	17.53	22.17	21.19	21.71	23.12	20.56
7%	14.77	18.41	17.21	17.64	19.00	16.94
8%	12.70	15.58	14.22	14.59	15.92	14.22
9%	11.08	13.38	11.89	12.22	13.52	12.10
10%	9.800	11.62	10.03	10.32	11.60	10.41

The typical value of R_{trim_down}

	5V	12V	15V	24V	28V	48V
Trim down%	R _{trim_down}					
1%	111.8	687.3	952.0	1703	2066	3294
2%	53.88	327.1	452.0	807.8	987.4	1588
3%	34.55	207.0	285.3	509.2	627.7	1019
4%	24.88	147.0	202.0	359.9	447.8	735.1
5%	19.08	110.9	152.0	270.3	339.9	564.5
6%	15.21	86.96	118.6	210.6	268.0	450.7
7%	12.45	69.81	94.85	167.9	216.6	369.5
8%	10.38	56.95	77.00	135.9	178.0	308.5
9%	8.769	46.94	63.11	111.0	148.1	261.1
10%	7.480	38.94	52.00	91.16	124.1	223.2
11%	6.425	32.39	42.90	74.87	104.5	192.2
12%	5.547	26.93	35.33	61.30	88.16	166.3
13%	4.803	22.31	28.92	49.82	74.33	144.5
14%	4.166	18.35	23.42	39.97	62.47	125.7
15%	3.613	14.92	18.66	31.44	52.19	109.5
16%	3.130	11.92	14.50	23.97	43.20	95.28
17%	2.704	9.277	10.82	17.39	35.26	82.73
18%	2.324	6.923	7.556	11.53	28.21	71.58
19%	1.985	4.817	4.632	6.298	21.90	61.60
20%	1.680	2.921	2.000	1.583	16.22	52.62

6.11 Output Remote Sensing

The CFDQG150-300S series converter has the capability to remotely sense both lines of its output. This feature moves the effective output voltage regulation point from the output of the unit to the point of connection of the remote sense pins. This feature automatically adjusts the real output voltage of the CFDQG150-300S series in order to compensate for voltage drops in distribution and maintain a regulated voltage at the point of load. The remote-sense voltage range is:

$$[(+V_{out}) - (-V_{out})] - [(+Sense) - (-Sense)] \leq 10\% \text{ of } V_{o_nominal}$$

When remote sense is in use, the sense should be connected by twisted-pair wire or shield wire. If the sensing patterns short, heavy current flows and the pattern may be damaged. Output voltage might become unstable because of impedance of wiring and load condition when length of wire is exceeding 400mm. This is shown in the schematic below.

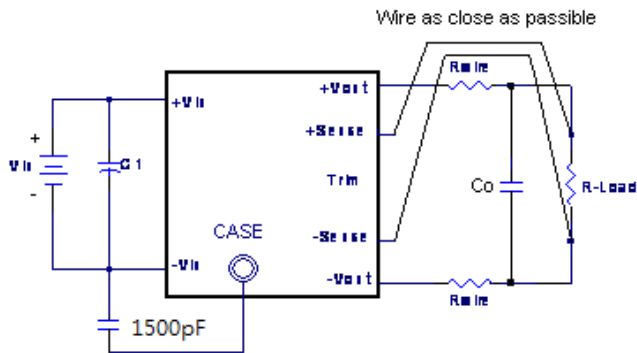

If the remote sense feature is not to be used, the sense pins should be connected locally. The +Sense pin should be connected to the +Vout pin at the module and the -Sense pin should be connected to the -Vout pin at the module. Wire between +Sense and +Vout and between -Sense and -Vout as short as possible. Loop wiring should be avoided. The converter might become unstable by noise coming from poor wiring. This is shown in the schematic below.

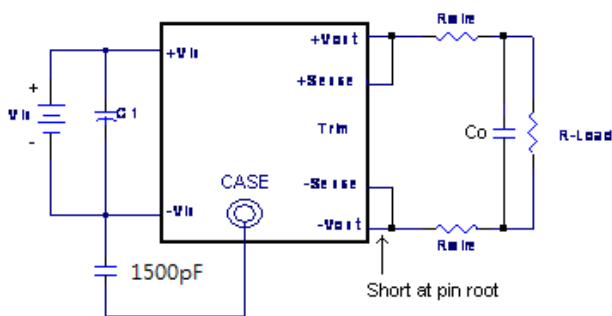

Note: Although the output voltage can be varied (increased or decreased) by both remote sense and trim, the maximum variation for the output voltage is the larger of the two values not the sum of the values. The output power delivered by the module is defined as the voltage at the output terminals multiplied by the output current. Using remote sense and trim can cause the output voltage to increase and consequently increase the power output of the module if output current remains unchanged. Always ensure that the output power of the module remains at or below the maximum rated power. Also be aware that if $V_{o.set}$ is below nominal value, $P_{out.max}$ will also decrease accordingly.

because $I_{o.max}$ is an absolute limit. Thus, $P_{out.max} = V_{o.set} \times I_{o.max}$ is also an absolute limit.

6.12 Output Ripple and Noise

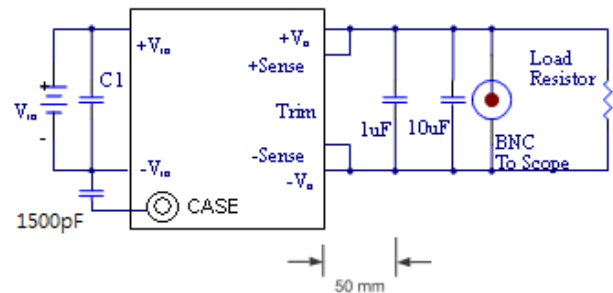

Output ripple and noise measured with 10uF aluminum and 1uF ceramic capacitor across output for 48V_{out} and with 10uF tantalum and 1uF ceramic capacitor for others. A 20 MHz bandwidth oscilloscope is normally used for the measurement.

The conventional ground clip on an oscilloscope probe should never be used in this kind of measurement. This clip, when placed in a field of radiated high frequency energy, acts as an antenna or inductive pickup loop, creating an extraneous voltage that is not part of the output noise of the converter.



Another method is shown in below, in case of coaxial-cable/BNC is not available. The noise pickup is eliminated by pressing scope probe ground ring directly against the -Vout terminal while the tip contacts the +Vout terminal. This makes the shortest possible connection across the output terminals.

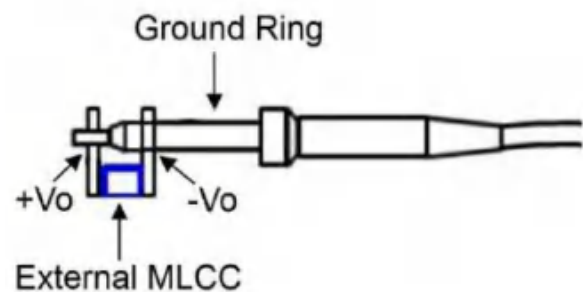

6.13 Output Capacitance

The CFDQG150-300S series converters provide unconditional stability with or without external capacitors. For good transient response, low ESR output capacitors should be located close to the point of load (<100mm). PCB design emphasizes low resistance and inductance tracks in consideration of high current applications. Output capacitors with their associated ESR values have an impact on loop stability and bandwidth. Chewins's converters are designed to work with load capacitance to see technical specifications.

6.14 Remote On/Off Circuit

The converter remote On/Off circuit built-in on input side. The ground pin of input side Remote On/Off circuit is -Vin pin. Refer to 5.5 for more details. Inside connection examples see below.

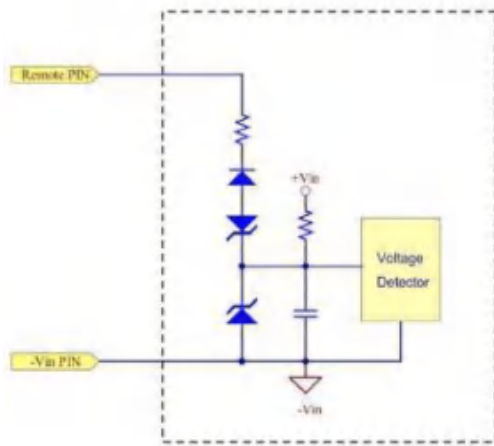

Inside Remote On/Off Circuit Schematic

External connection examples see below.

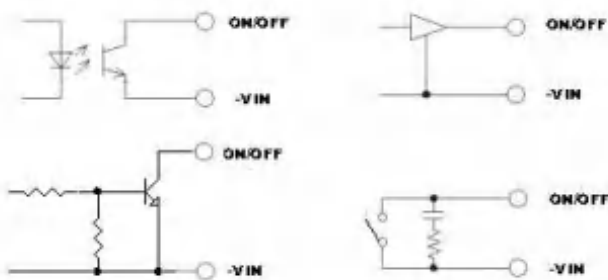

External Remote On/Off Connection Example

6.15 Series Operation

Series operation is possible by connecting the outputs two or more units. Connection is shown in below. The output current in series connection should be lower than the lowest rate current in each power module.

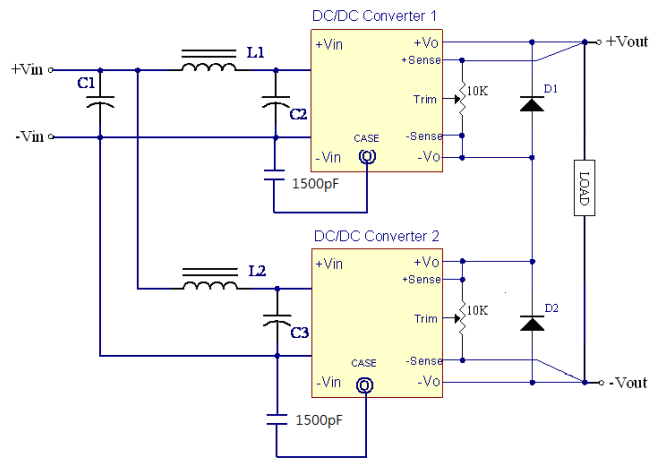

Simple Series Operation Connect Circuit

L1, L2: 1.0uH

C1, C2, C3: 68uF/450V ESR<0.7Ω

Note:

- 1.If the impedance of input line is high,C1,C2,C3 capacitance must be more than above.Use more than two recommended capacitor above in parallel when ambient temperature becomes lower than -20°C.
- 2.Recommend Schottky diode (D1,D2)be connected across the output of each series connected converter, so that if one converter shuts down for any reason, then the output stage won't be thermally overstressed. Without this external diode,the output stage of the shut-down converter could carry the load current provided by the other series converters,with its MOSFETs conducting through the body diodes.The MOSFETs could then be overstressed and fail.The external diode should be capable of handling the full load current for as long as the application is expected to run with any unit shut down.

Series for ±output operation is possible by connecting the outputs two units,as shown in the schematic below.

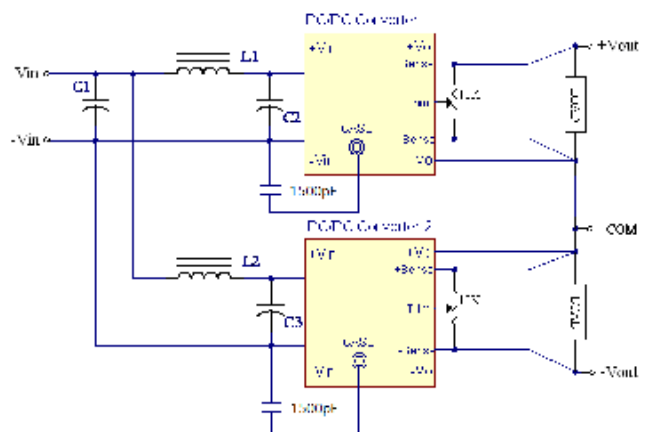

Simple ±Output Operation Connect Circuit

L1,L2:1.0uH

C1,C2,C3:68uF/450V ESR<0.7Ω

Note:

If the impedance of input line is high, C1,C2,C3 capacitance must be more than above. Use more than two recommended capacitor above in parallel when ambient temperature becomes lower than -20°C.

6.16 Parallel/Redundant Operation

The CFDQG150-300S series parallel operation is not possible. Parallel for redundancy operation is possible by connecting the units as shown in the schematic below. The current of each converter become unbalance by a slight difference of the output voltage. Make sure that the output voltage of units of equal value and the output current from each power supply does not exceed the rate current. Suggest use an external potentiometer to adjust output voltage from each power supply.

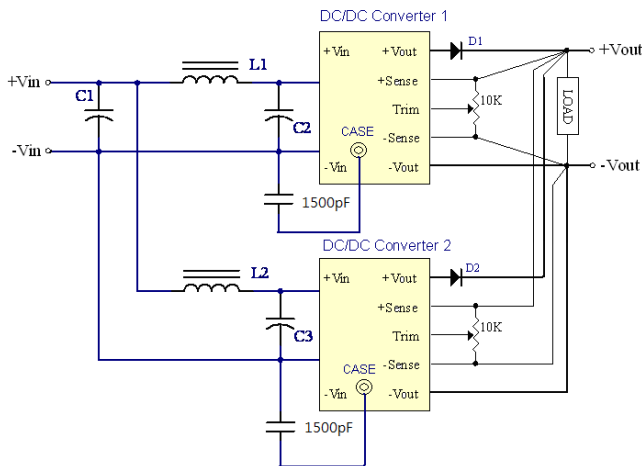

Simple Redundant Operation Connect Circuit

L1, L2: 1.0uH

C1, C2, C3: 68uF/450V ESR<0.7Ω

Note:

If the impedance of input line is high, C1, C2, C3 capacitance must be more than above. Use more than two recommended capacitor above in parallel when ambient temperature becomes lower than -20°C.

7. Safety/EMC

7.1 Input Fusing and Safety Considerations

The CFDQG150-300S series converters have no internal fuse. In order to achieve maximum safety and system protection, always use an input line fuse. We recommended a 2A time delay fuse for all models. It is recommended that the circuit have a transient voltage suppressor diode (TVS) across the input terminal to protect the unit against surge or spike voltage and input reverse voltage (as shown).

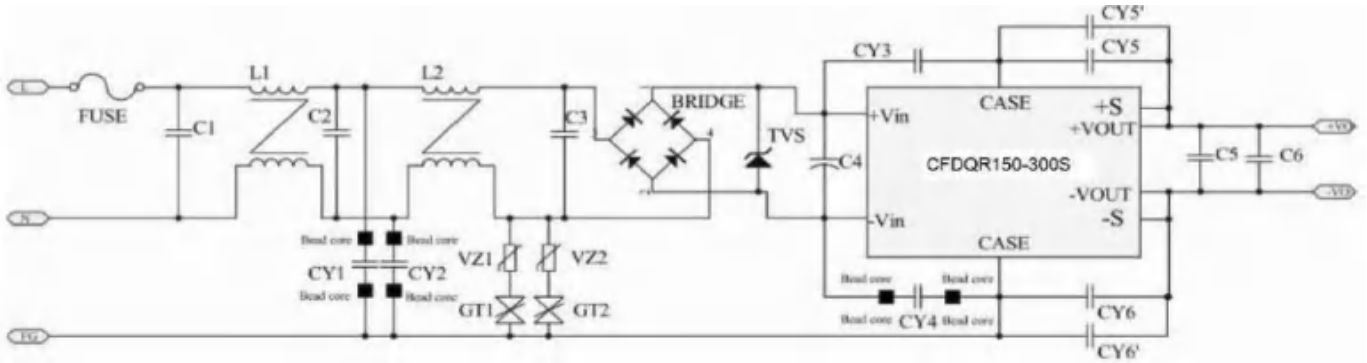

Connection circuit for Input Fusing and Safety Considerations

The external circuit is required if CFDQG150-300S series has to meet EN61000-4-4, EN61000-4-5.

The CFDQG150-300S recommended components are shown below.

C4: 68uF/450V aluminum capacitor (Nippon Chemi-Con KXG series).

TVS: SMCJ440A Littelfuse

VZ1, VZ2: TVR10471KSV TKS

GT1, GT2: B5G3000 BENCENT

7.2 AC INPUT EMC Considerations

EMI Test standard: EN55022/EN55032 Class A Conducted Emission

Test Condition: Input Voltage: 220VAC, Output Load: Full Load

(1) EMI and conducted noise meet EN55032 Class A:

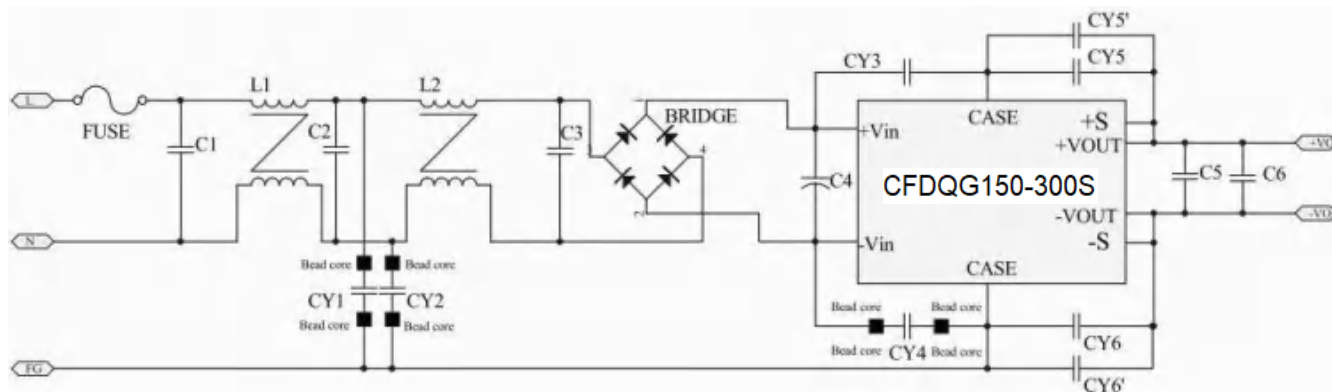

Figure1 Connection circuit for conducted EMI Class A testing

	Model Number					
	CFDQG150-300S05	CFDQG150-300S12	CFDQG150-300S15	CFDQG150-300S24	CFDQG150-300S28	CFDQG150-300S48
C1	0.68uF/305V					
C2	X2 Cap.					
C3	MKP62(C42)					
C4	68uF/450V Aluminum Cap. KXG series					
C5	10uF/50V X7R 2220					4.7uF/100V X7R 2220
C6	1uF/50V X7R 1210					1uF/100V X7R 1210
L1	URT24-050055H 5mH/5A					
L2	URT24-050055H 5mH/5A					
BRIDGE	S10GBU80-C 800V 10A					
CY1	1000pF					
CY2	1000pF					
CY3	1500pF					
CY4	1500pF					
CY5, CY5'	4700pF					
CY6, CY6'	4700pF					

Note:

1. CY1, CY2, CY4 Bead Core: BRH 4*1.5*2 CHILISIN

2. CY1 to CY6 as above all Capacitors: Type CD Series TDK

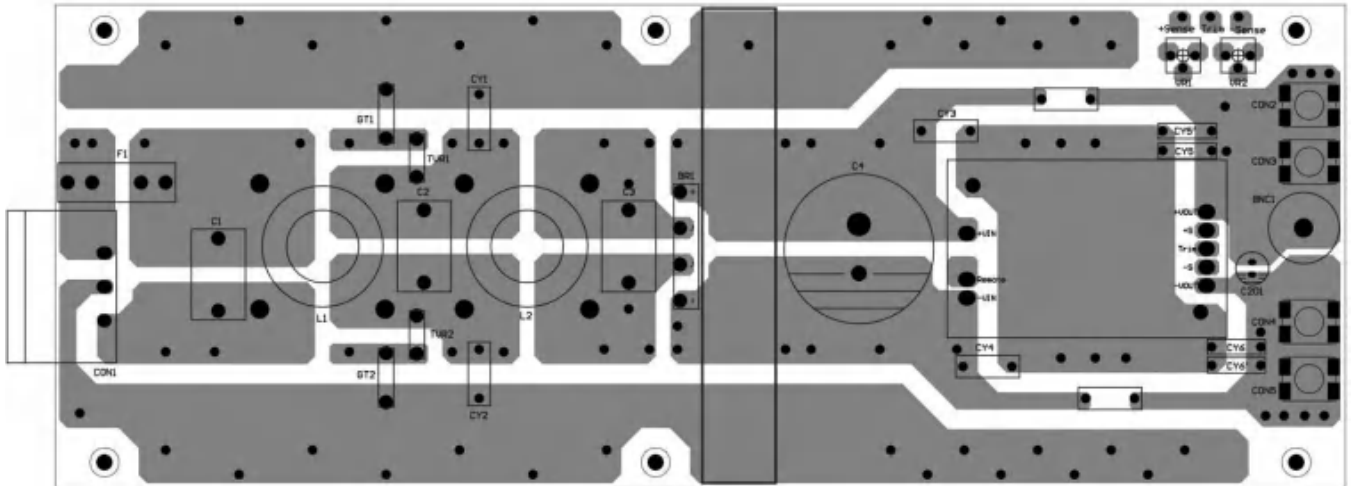

EMI test board top side

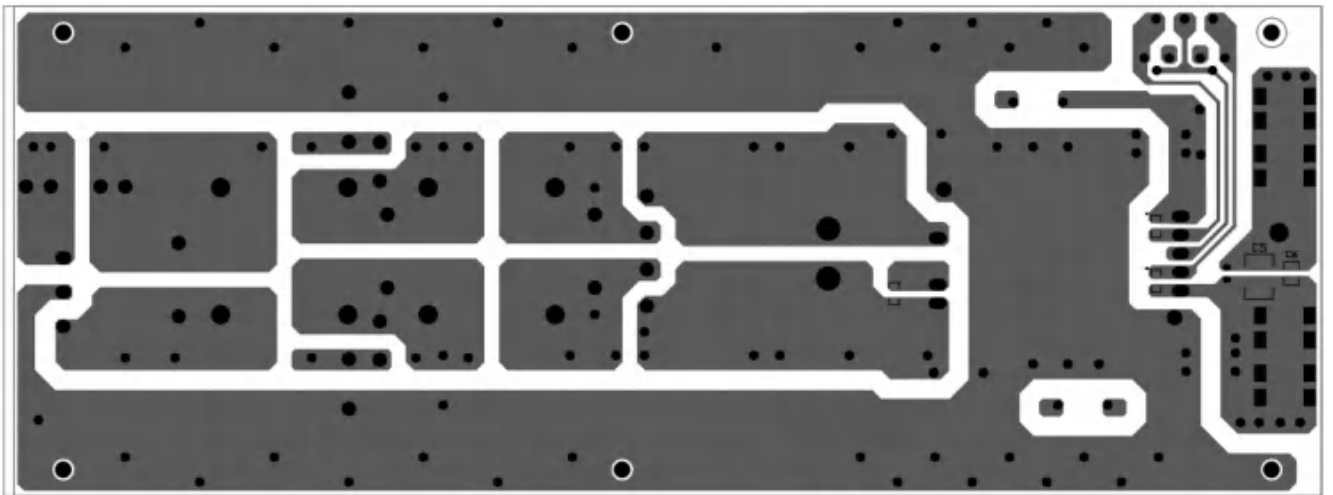

EMI test board bottom side

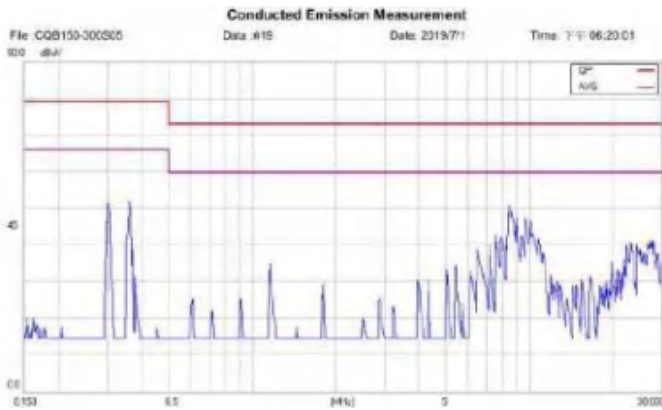

Conducted Class A of CFDQG150-300S05 Line

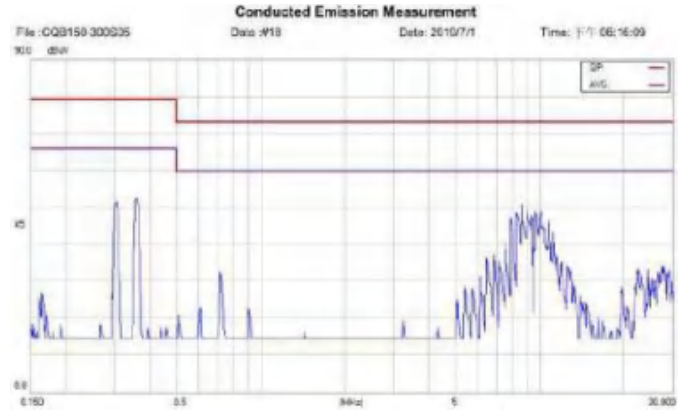

Conducted Class A of CFDQG150-300S05 Nature



Conducted Class A of CFDQG150-300S12 Line

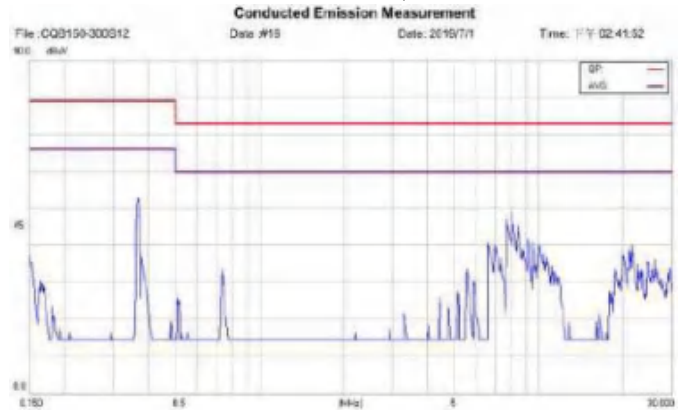

Conducted Class A of CFDQG150-300S12 Nature

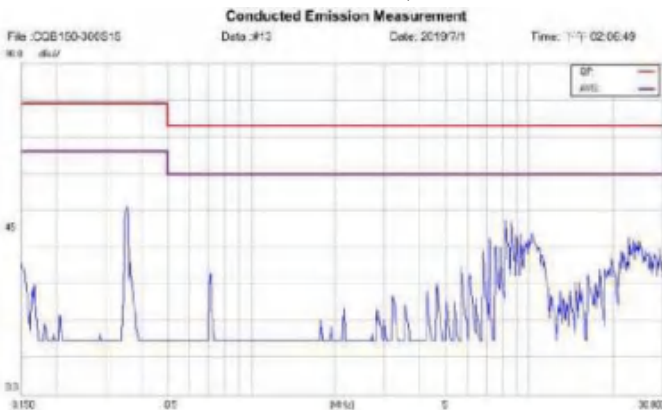

Conducted Class A of CFDQG150-300S15 Line

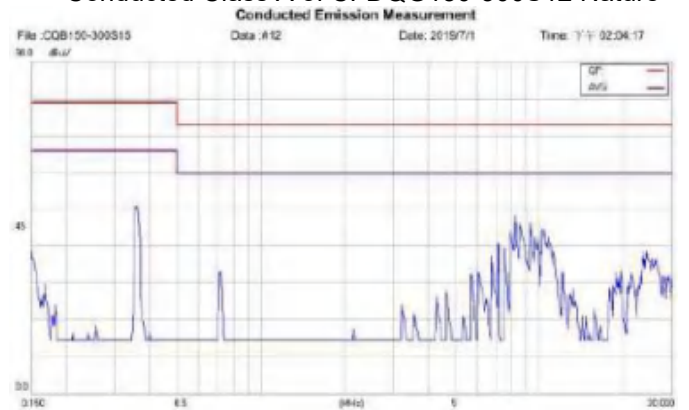

Conducted Class A of CFDQG150-300S15 Nature

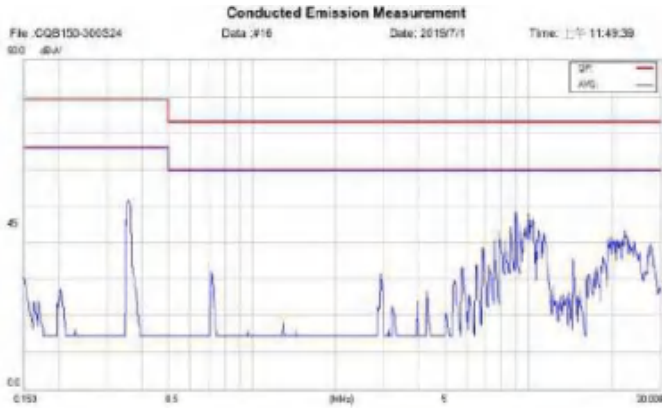

Conducted Class A of CFDQG150-300S24 Line

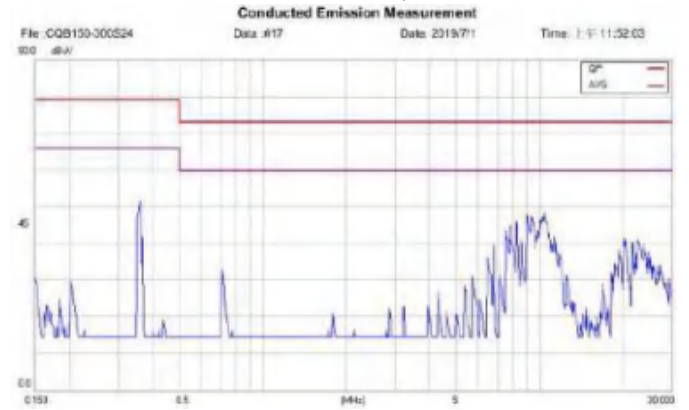

Conducted Class A of CFDQG150-300S24 Nature

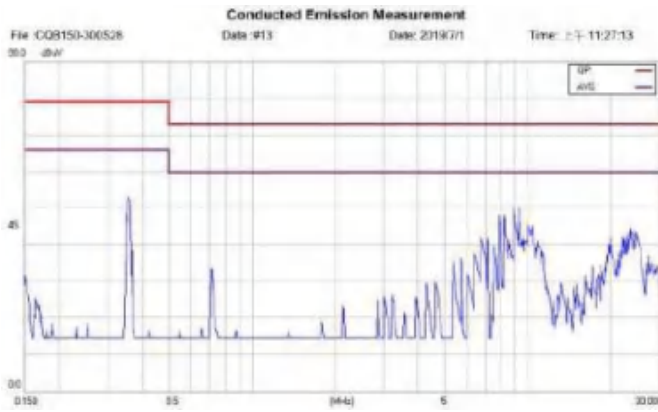

Conducted Class A of CFDQG150-300S28 Line

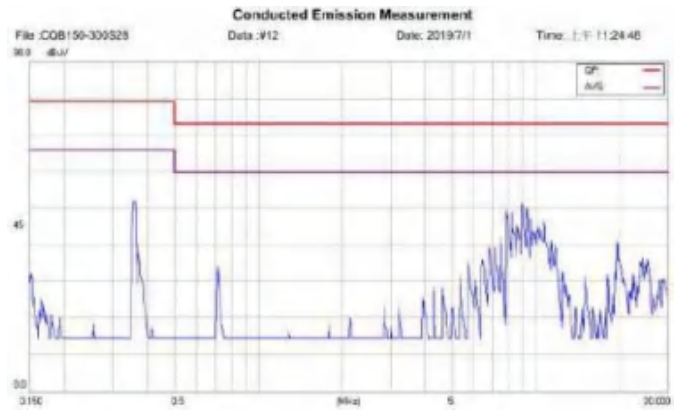

Conducted Class A of CFDQG150-300S28 Nature

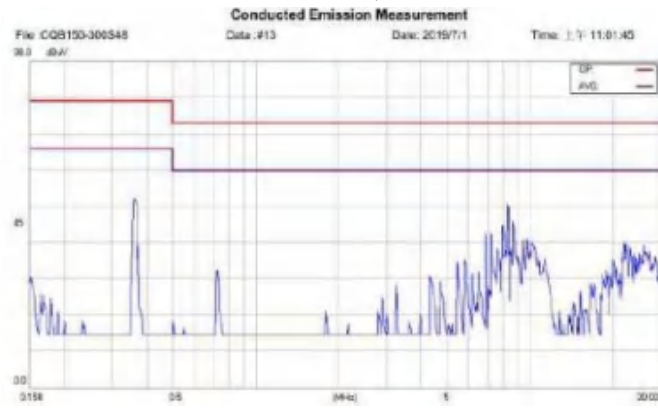

Conducted Class A of CFDQG150-300S48 Line

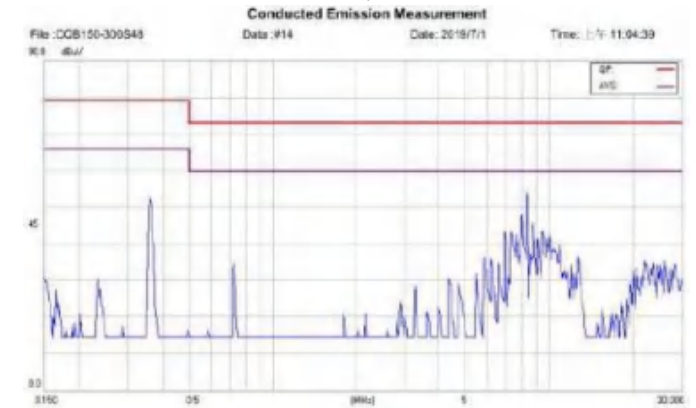

Conducted Class A of CFDQG150-300S48 Nature

7.3 DC INPUT EMC Considerations

EMI Test standard: EN55022/EN55032 Class A Conducted Emission

Test Condition: Input Voltage: 300VDC, Output Load: Full Load

(1) EMI and conducted noise meet EN55032 Class A:

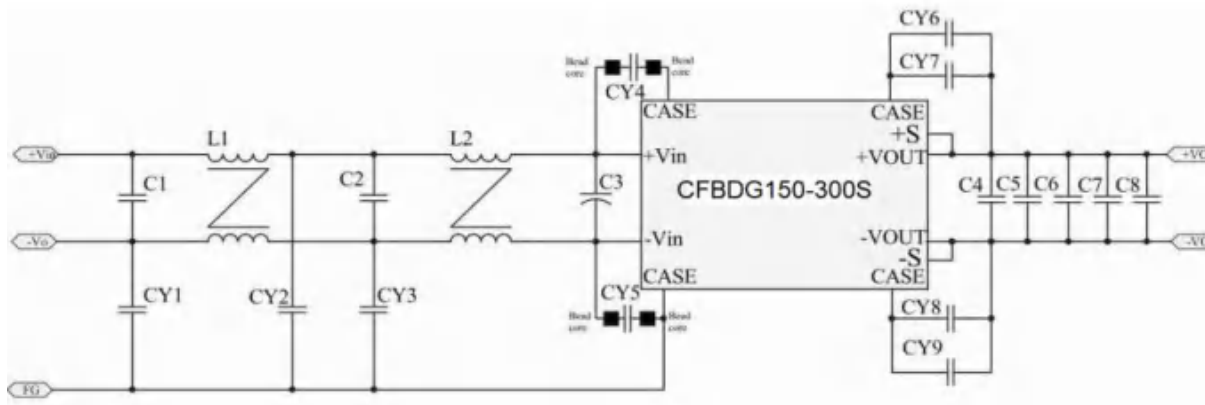
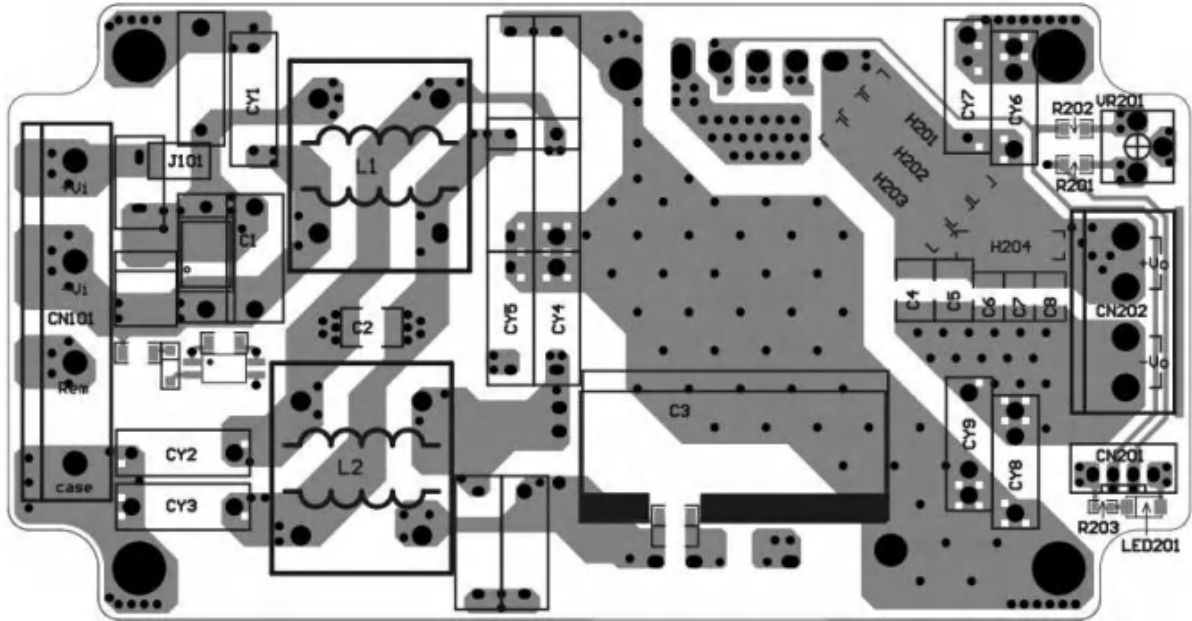
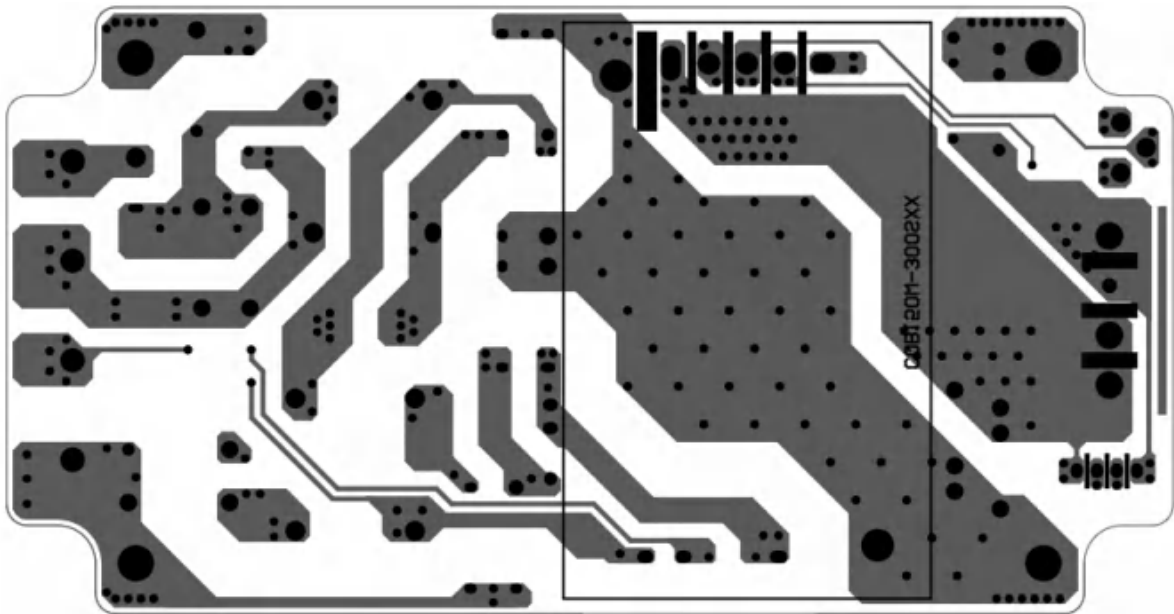

Figure2 Connection circuit for conducted EMI Class A testing

Part Number	VALUE
C1	0.47uF/520V Polyester Film Capacitor MPN2 Type HJC
C2	0.1uF/630V 1812 X7R
C3	33uF/450V Aluminum Capacitor KXJ Series Nippon Chemi-Con
C4,C5	4.7uF/100V X7R 1812
C6,C7,C8	0.47uF/250V X7R 1210
CY1, CY2	100pF CD Type Y1 CAP TDK
CY3	1000pF CD Type Y1 CAP TDK
CY4, CY5	1500pF CD Type Y1 CAP TDK
CY6, CY7, CY8, CY9	4700pF CD Type Y1 CAP TDK
L1, L2	5mH
CY4, CY5 Bead Core	SN30 T2.8*1.7*2 SM



EMI test board top side



EMI test board bottom side

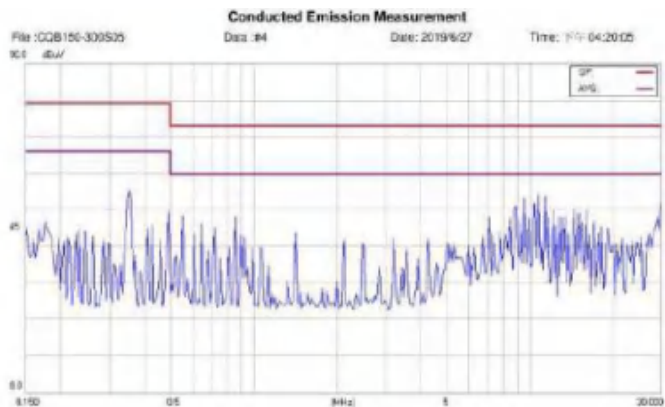

Conducted Class A of CFDQG150-300S05 Line

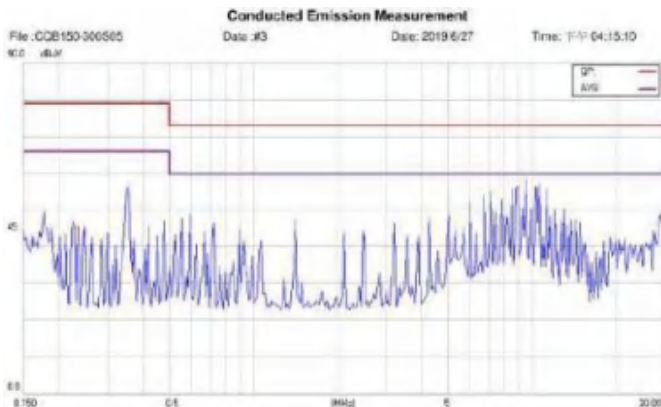

Conducted Class A of CFDQG150-300S05 Nature

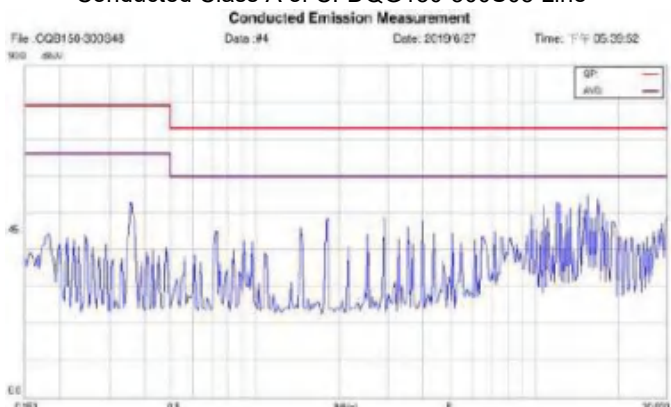

Conducted Class A of CFDQG150-300S12 Line



Conducted Class A of CFDQG150-300S12 Nature

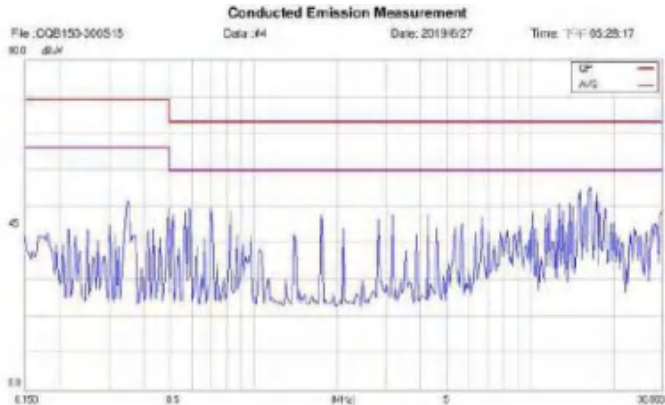

Conducted Class A of CFDQG150-300S15 Line

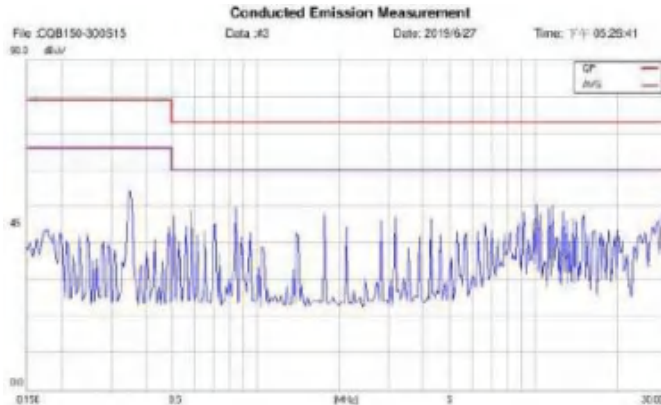

Conducted Class A of CFDQG150-300S15 Nature

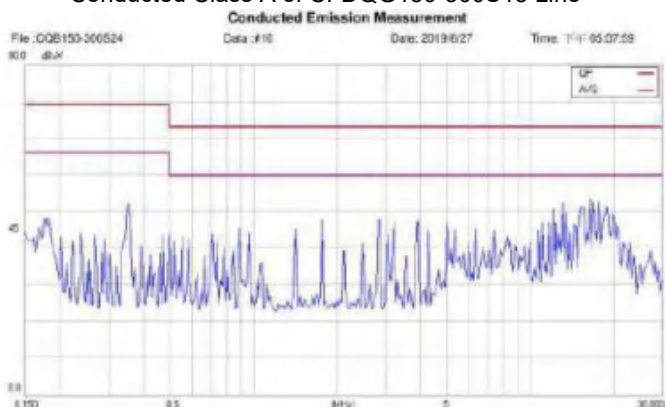

Conducted Class A of CFDQG150-300S24 Line

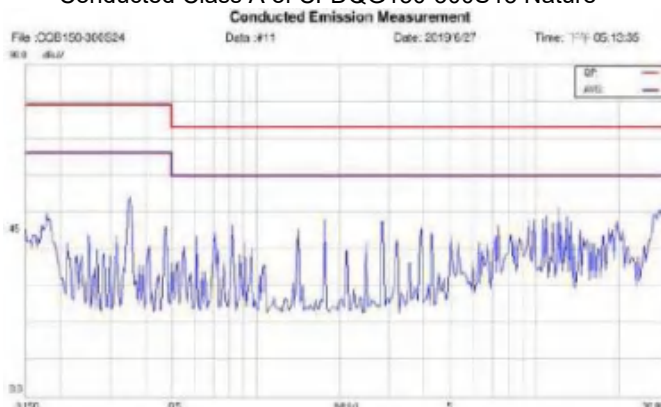

Conducted Class A of CFDQG150-300S24 Nature

Dimensions and Recommended Layout

THIRD ANGLE PROJECTION

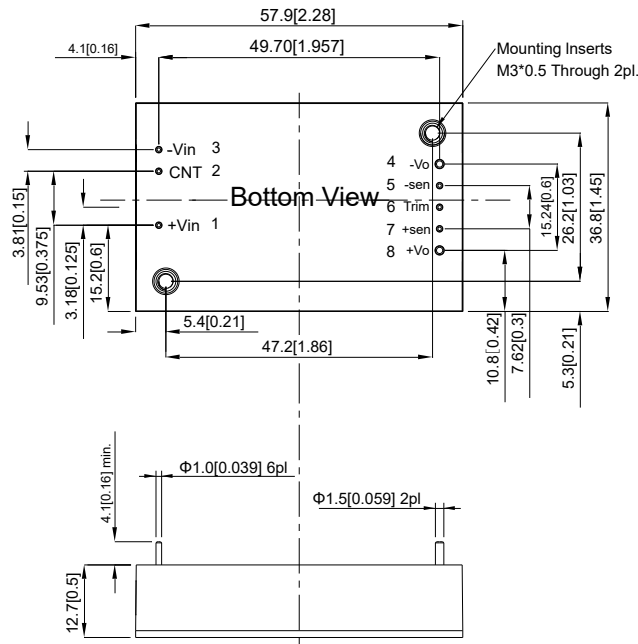

Note:
 Unit:mm[inch]
 Mounting rail:TS35
 Wire range:24-12AWG
 Tightening torque:Max 0.4N•m
 General tolerances:±1.0[±0.039]



Beijing Huayang Changfeng Technology Co.,Ltd.

Address: No. 25, torch South Street, Zhuozhou Development Zone, Hebei Province, people's Republic of China

Tel:86-10-68817997

Mobile phone:15600309099

E-mail:sales@chewins.net